

R88D-GN□

G-Series servo drive

A compact servo drive family for motion control. Compact size and integrated MECHATROLINK-II motion bus.

- High-response frequency of 1 kHz
- Auto-tuning for easy and quick start-up
- Vibration suppression
- Positioning, speed or torque control
- Separate power and control power supply
- Fast and accurate positioning
- Incremental and absolute encoder



Ratings

- 230 VAC Single-phase 100 W to 1.5 kW (8.62 Nm)

System configuration

G-Series MECHATROLINK-II Servo Drive Configuration

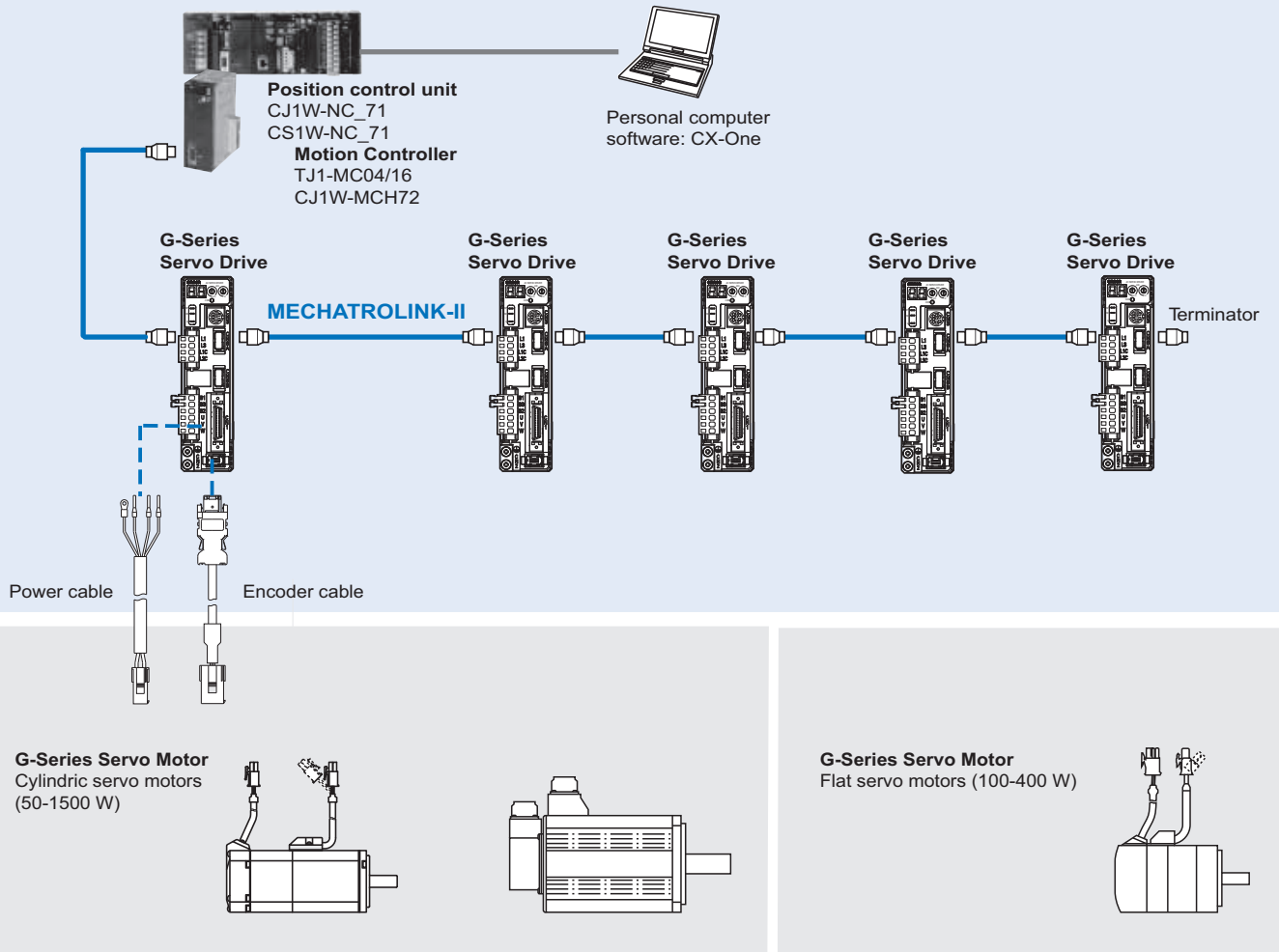

Servo motor supported

Servo motor								G-Series servo drive	
Family	Power	Image	Voltage	Speed	Rated torque	Capacity	Model		
Cylindric	50 - 750 W		230 V	3000 min ⁻¹	0.16 Nm	50 W	R88M-G05030□-□S2	R88D-GN01H-ML2	
					0.32 Nm	100 W	R88M-G10030□-□S2	R88D-GN01H-ML2	
					0.64 Nm	200 W	R88M-G20030□-□S2	R88D-GN02H-ML2	
					1.3 Nm	400 W	R88M-G40030□-□S2	R88D-GN04H-ML2	
					2.4 Nm	750 W	R88M-G75030□-□S2	R88D-GN08H-ML2	
	900 - 1500 W				3.18 Nm	1000 W	R88M-G1K030T-□S2	R88D-GN15H-ML2	
					4.77 Nm	1500 W	R88M-G1K530T-□S2	R88D-GN15H-ML2	
					2000 min ⁻¹	4.8 Nm	1000 W	R88M-G1K020T-□S2	R88D-GN10H-ML2
					7.15 Nm	1500 W	R88M-G1K520T-□S2	R88D-GN15H-ML2	
					1000 min ⁻¹	8.62 Nm	900 W	R88M-G90010T-□S2	R88D-GN15H-ML2
Flat	100-400 W		230 V	3000 min ⁻¹	0.32 Nm	100 W	R88M-GP10030□-□S2	R88D-GN01H-ML2	
					0.64 Nm	200 W	R88M-GP20030□-□S2	R88D-GN02H-ML2	
					1.3 Nm	400 W	R88M-GP40030□-□S2	R88D-GN04H-ML2	

Type designation

Servo drive

R88D-GN04H-ML2

G-Series servo drive

N: Network type

Capacity

01	100 W
02	200 W
04	400 W
08	750 W
10	1.0 kW
15	1.5 kW

Model

ML2: MECHATROLINK-II communications

Source voltage

H: 230 V

Servo drive specifications

G-Series servo drive

Servo drive type	R88D-GN□	01H-ML2	02H-ML2	04H-ML2	08H-ML2	10H-ML2	15H-ML2		
Applicable servomotor	R88M-G□	05030□/10030□	20030□	40030□	75030□	G1K020T□	90010T□ / 1K030T□ / 1K5□0T□		
	R88M-GP□	10030□	20030□	40030□	-	-	-		
Basic specifications	Max. applicable motor capacity	W	100	200	400	750	1000	1500	
	Continuous output current	Arms	1.16	1.6	2.7	4.0	5.9	9.8	
	Max. output current	Arms	3.5	5.3	7.1	14.1	21.2	28.3	
	Input power	Main circuit	For single-phase, 200 to 240 VAC +10 to -15% (50/60 Hz)			For single-phase/ three-phase, 200 to 240 VAC +10 to -15% (50/60 Hz)			
	Supply	Control circuit	For single-phase, 200 to 240 VAC + 10 to -15% (50/60 Hz)						
	Control method	IGBT-driven PWM method							
	Feedback	Serial encoder (incremental/absolute)							
	Conditions	Usage/storage temperature	0 to +55 °C / -20 to 65 °C						
		Usage/storage humidity	90% RH or less (non-condensing)						
		Altitude	1000m or less above sea level						
Vibration/shock resistance		5.88 m/s ² / 19.6 m/s ²							
Configuration	Base mounted								
Approx. weight	Kg	0.8	1.1	1.5	1.7				
Position/Speed/torque control mode	Speed control range	1:5000							
	Speed variance	Load variance	During 0 to 100% load ±0.01 max. (at rated speed)						
		Voltage variance	0% at ±10% of rated voltage (at rated speed)						
		Temperature variance	0 to 50°C ±0.1% max. (at rated speed)						
	Frequency characteristics	1 kHz							
	Torque control accuracy (reproducibility)	±3% (at 20% to 100% of rated torque)							
Soft start time setting	0 to 10 s (acceleration time and deceleration time can be set)								
Command input	MECHATROLINK Communication	MECHATROLINK-II commands (for sequence, motion, data setting/reference, monitor, adjustment and other commands)							

Servo drive type	R88D-GN□	01H-ML2	02H-ML2	04H-ML2	08H-ML2	10H-ML2	15H-ML2	
Applicable servomotor	R88M-G□	05030□/10030□	20030□	40030□	75030□	G1K020T□	90010T□ / 1K030T□ / 1K5□0T□	
	R88M-GP□	10030□	20030□	40030□	-	-	-	
I/O signal	Sequence input signal		Emergency stop, 3 external latch signals, forward/reverse torque limit, forward/reverse run prohibit, origin proximity, 3 general-purpose inputs					
	Sequence output signal		It is possible to output three types of signals: positioning completed, speed coincidence, rotation speed detection, servo ready, current limit, speed limit, brake release and warning signal					
Communications	RS-232 communications	Interface	Personal computer					
		Transmission rate	From 2400 to 57600 bps					
		Functions	Parameter setting, status display, alarm display (monitor, clear, history), servo drive data tracing function, test run/autotuning operations, real time trace, absolute encoder setting, default values function					
	MECHATROLINK communications	Communications protocol	MECHATROLINK-II					
Transmission rate		10 Mbps						
Data length		32 bytes						
Integrated functions	Functions		Parameter setting, status display, alarm display (monitor, clear, history), default values function					
	Automatic load inertia detection		Horizontal and vertical axis mode. One parameter rigidity setting.					
	Dynamic brake (DB)		Operates when main power OFF, servo alarm, overtravel or servo OFF					
	Regenerative processing		Built-in regeneration resistor in models from 750 W to 1.5 kW. External regeneration resistor optionally.					
	Overtravel (OT) prevention function		Dynamic brake, disables torque or emergency stop torque during POT and NOT operation					
	Emergency stop (STOP)		Emergency stop input					
	Encoder divider function		Optional division pulses possible					
	Electronic gearing		0.01 < Numerator/Denominator < 100					
	Internal speed setting function		8 internal speeds					
	Protective functions		Overvoltage, undervoltage, overcurrent, overload, regeneration overload, servo drive overheat					
	Analog monitor Output		The actual servomotor speed, command speed, torque and number of accumulated pulses can be measured using an oscilloscope or other device.					
	Panel operator	Display functions		A 2-digit 7-segment LED display shows the servo drive status, alarm codes, parameters, etc. MECHATROLINK-II communications status LED indicator (COM)				
		Switches		Rotary switch for setting the MECHATROLINK-II node address				

Servo drive part names

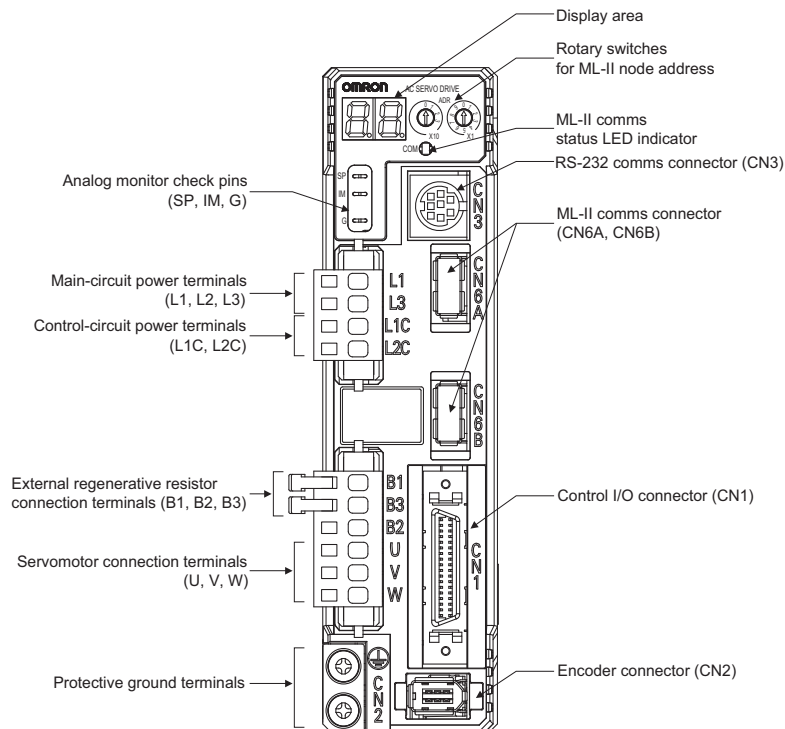

I/O specifications

Main circuit connector (CNA) specifications

Symbol	Name	Function
L1	Main circuits power supply input	AC power input terminals for the main circuit
L2		
L3		
L1C	Control circuit power supply input	AC power input terminals for the control circuit
L2C		

Servomotor connector (CNB) specifications

Symbol	Name	Function
B1	External regeneration resistor connection terminals	Up to 400 W: If regenerative energy is high, connect an External Regeneration Resistor between B1 and B2. From 750 W to 1.5kW: Normally B2 and B3 are connected. If regenerative energy is high, remove the short-circuit bar between B2 and B3 and connect an External Regeneration Resistor between B1 and B2.
B2		
B3		
U	Servo motor connection terminals	Terminals for outputs to the servomotor.
V		
W		
⊕		
⊕	Frame ground	Ground terminal. Ground to 100Ω or less.

I/O signals (CN1) - Input signals

Pin No.	Signal name	Function
1	+24VIN	Control power supply input for sequence signals: users must provide the +24 V power supply. Allowable voltage range: 12 to 24 VDC
2	STOP	Emergency Stop Input
3	EXT3	External Latch Signals
4	EXT2	
5	EXT1	
22	IN1	External general-purpose Input 0
6	IN0	External general-purpose Input 1
23	IN2	External general-purpose Input 2
7	PCL	Forward Torque Limit Input
8	NCL	Reverse Torque Limit Input
19	POT	Forward Run Prohibit Input
20	NOT	Reverse Run Prohibit Input
21	DEC	Origin Proximity Input
34	BAT	Battery backup input for absolute encoder
33	BATCOM	Connecting pin for the absolute backup battery. Do not connect when a battery is connected to the servomotor encoder cable.

I/O signals (CN1) - output signals

Pin No.	Signal name	Function
15	/ALM	The output turns OFF when an alarm is generated in the Servo drive.
16	ALMCOM	
29	OUTM2	General-purpose output. The function for this output is selected by changing the parameter: INP1 (Positioning completed), VCMP (Speed conformity signal), TGON (Servomotor rotation speed detection), READY (Servo ready), CLIM (Current limit detection), VLIM (Speed limit detection), BKIR (Brake interlock), WARN (Warning signal)
30	OUTM2COM	
31	OUTM3	
32	OUTM3COM	
36	OUTM1	
35	OUTM1COM	

Encoder connector (CN2)

Pin No.	Signal Name	Function
1	E5V	Encoder power supply + 5 V
2	E0V	Encoder power supply ground
3	BAT+	Battery + (used only with absolute encoder)
4	BAT-	Battery - (used only with absolute encoder)
5	PS+	Encoder serial signal input (+phase)
6	PS-	Encoder serial signal input (-phase)
Shell	FG	Shield ground

Serial connector (CN3)

Pin No.	Signal Name	Function
3	TXD	RS232 send data
4	GND	Ground
5	RXD	RS232 receive data

Dimensions

Servo drives

R88D-GN01H-ML2 / GN02H-ML2 (200 V, 100 to 200 W)

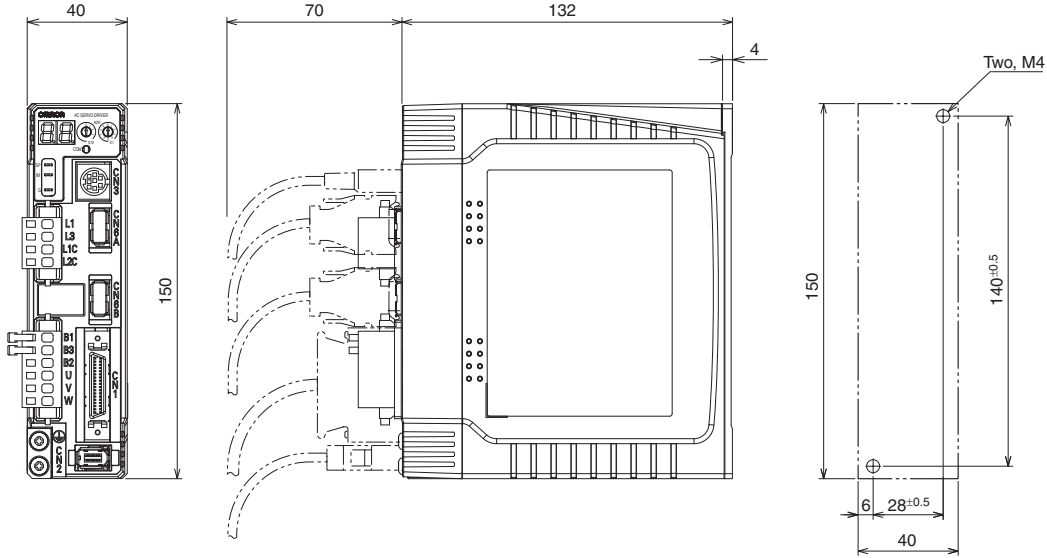

R88D-GN04H-ML2 (200 V, 400 W)

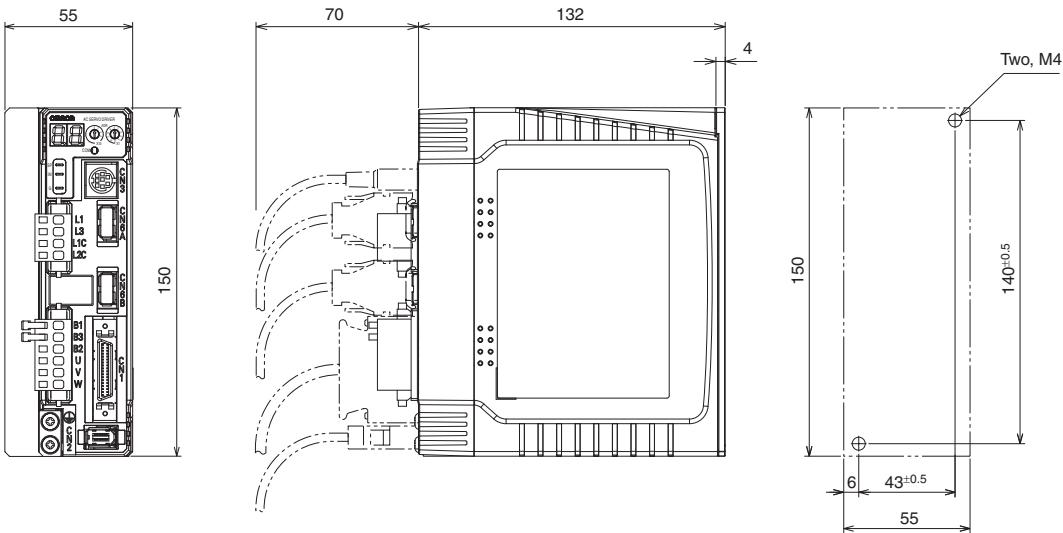

R88D-GN08H-ML2 (200 V, 750 W)

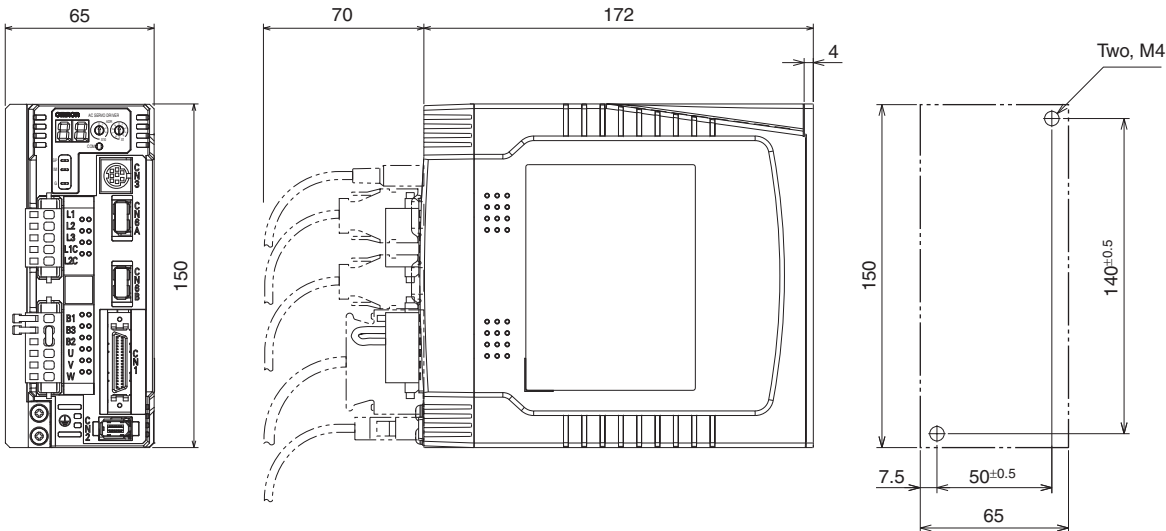

R88D-GN10H-ML2 / GN15H-ML2 (200 V, 1 kW to 1,5 kW)

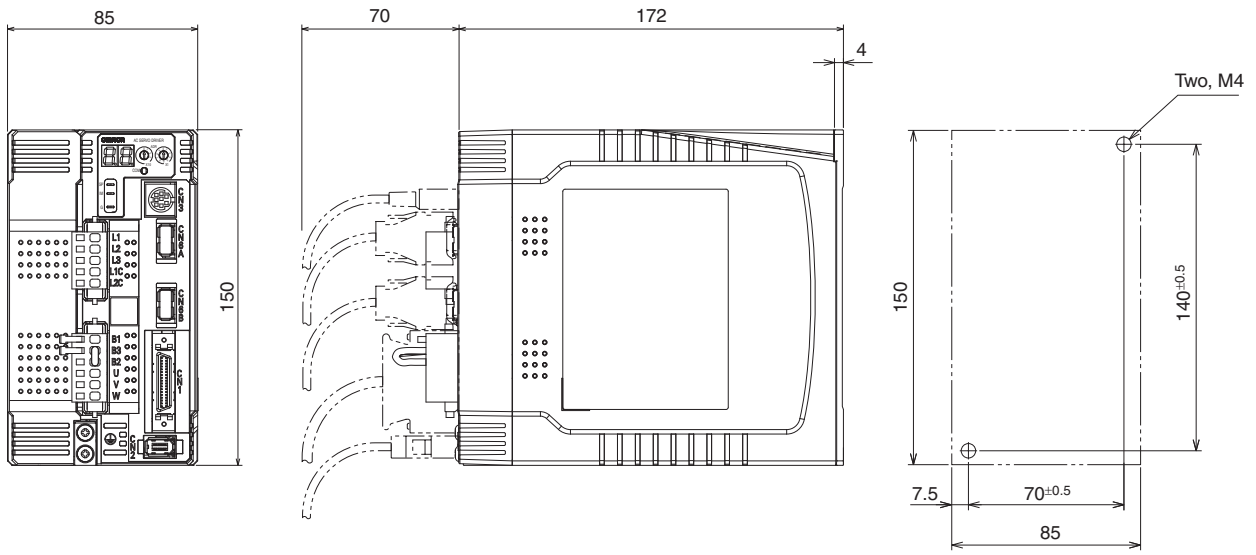

Filters

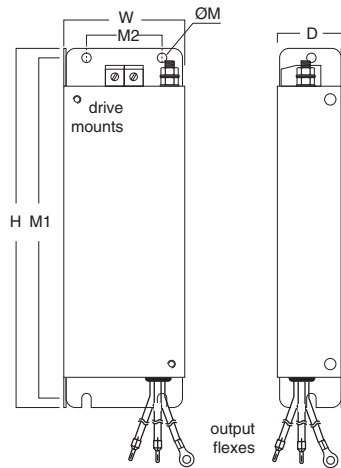

Filter model	Rated current	Leakage current	External dimensions			Mount dimensions		Filter Fixing	Rated voltage
			H	W	D	M1	M2		
R88A-FIK102-RE	2.4 A	3.5 mA	190	42	44	180	20	M4	250 VAC single-phase
R88A-FIK104-RE	4.1 A	3.5 mA	190	57	30	180	30	M4	
R88A-FIK107-RE	6.6 A	3.5 mA	190	64	35	180	40	M4	
R88A-FIK114-RE	14.2 A	3.5 mA	190	86	35	180	60	M4	

Installation

Single-phase, 230 VAC

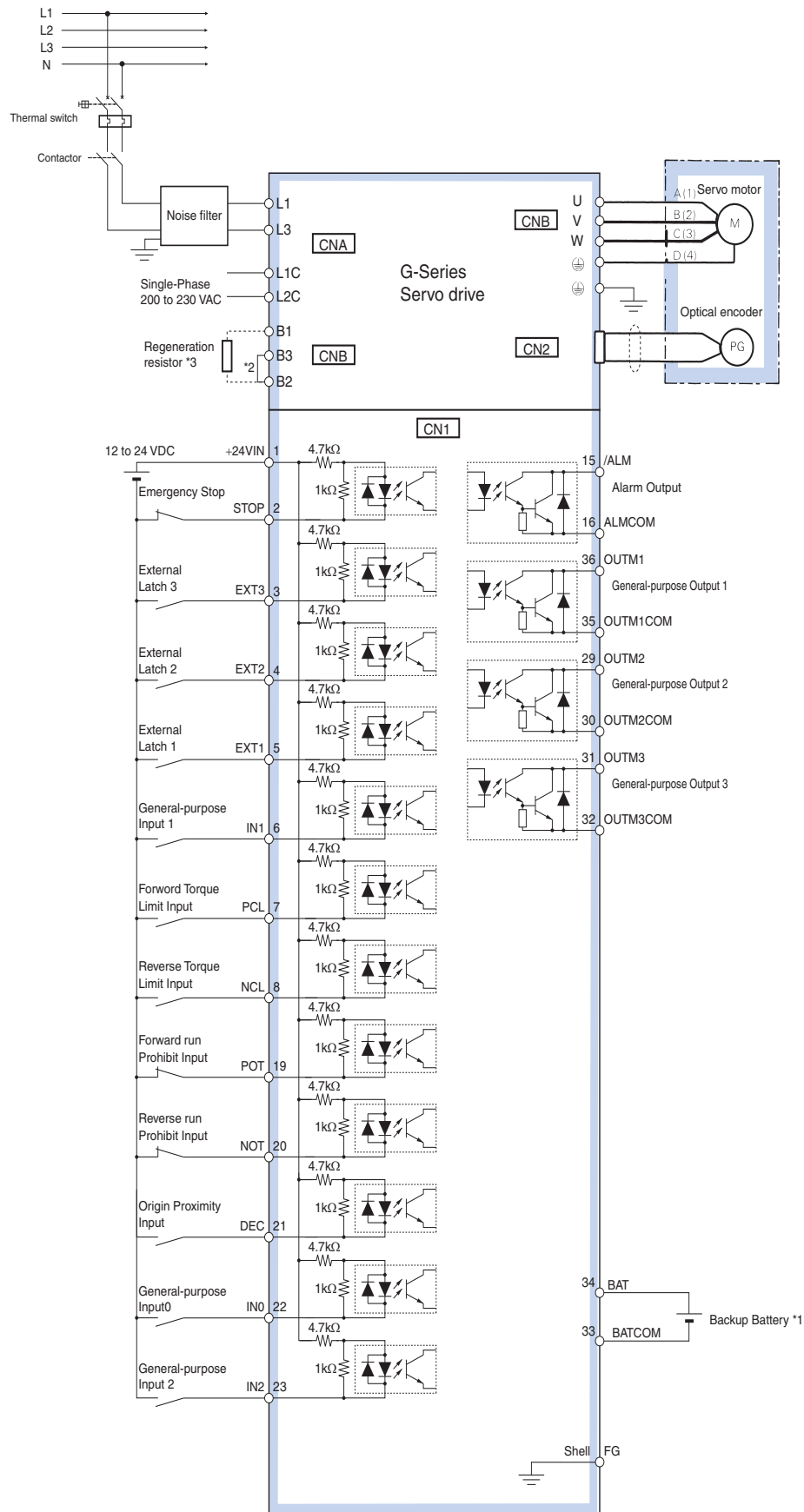

*1 Connect when using an absolute encoder. If a backup battery is connected, an encoder cable with a battery is not required.
 *2 Connect B2-B3 for the models with a built-in regeneration resistor (models from 750 W).
 *3 If the amount of regeneration is large, connect an external regeneration resistor to B1-B2. For the models from 750 W, disconnect B2-B3.

Ordering information

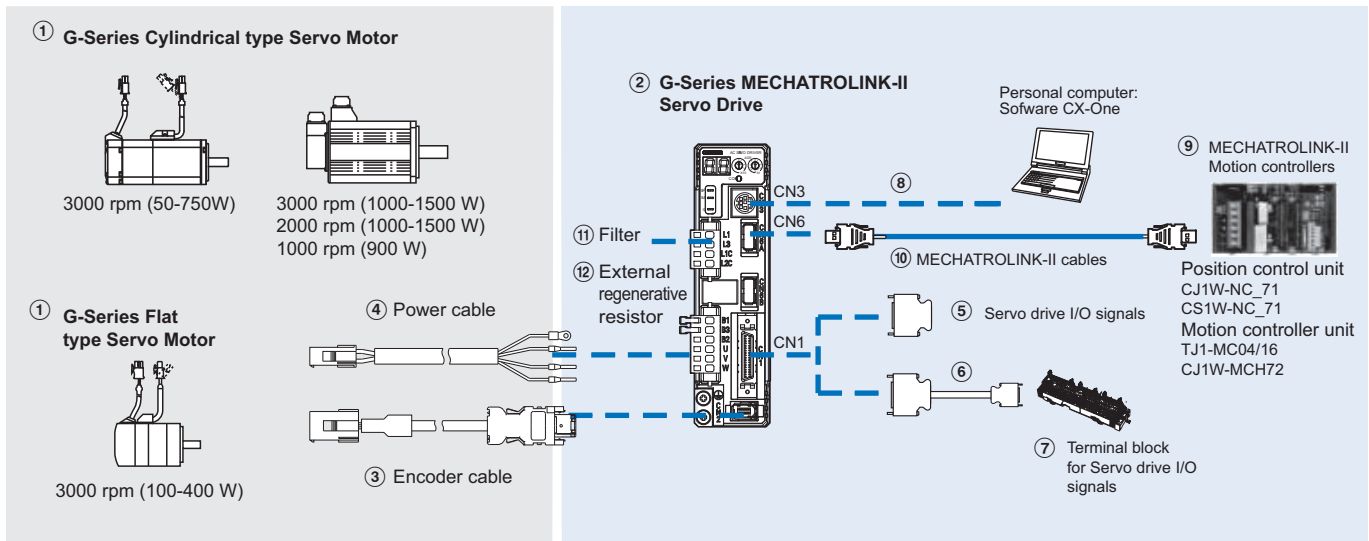

Note: The symbols ①②③④⑤... show the recommended sequence to select the components in a G-Series servo system

Servo motors, power & encoder cables

Note: ①③④ Refer to the G-Series servo motor chapter for servomotor, motor cables or connectors selection

Servo drives

Specifications	Servo drive model	① Compatible rotary servo motors		
		Cylindric type	Flat type	
1 phase 200 VAC	100 W	R88D-GN01H-ML2	R88M-G05030□ R88M-G10030□	R88M-GP10030□
	200 W	R88D-GN02H-ML2	R88M-G20030□	R88M-GP20030□
	400 W	R88D-GN04H-ML2	R88M-G40030□	R88M-GP40030□
	750 W	R88D-GN08H-ML2	R88M-G75030□	-
	1.0 kW	R88D-GN10H-ML2	R88M-G1K020T□ R88M-G1K030T□	-
	1.5 kW	R88D-GN15H-ML2	R88M-G1K520T□	-
			R88M-G1K530T□	-
			-	-

Control cables (for CN1)

Symbol	Name	Connect to	Model
⑤	I/O connector kit	Servo drive I/O signals	R88A-CNU01C
⑥	Terminal block cable		1 m XW2Z-100J-B33 2 m XW2Z-200J-B33
⑦	Terminal block		XW2B-20G4 XW2B-20G5 XW2D-20G6

Computer cable (for CN3)

Symbol	Name	Model
⑧	Computer cable RS232	2 m R88A-CCG002P2

MECHATROLINK-II Motion controllers

Symbol	Name	Model
⑨	Trajexia stand-alone motion controller	TJ1-MC04 (4 axes)
		TJ1-MC16 (16 axes)
	Trajexia-PLC motion controller	CJ1W-MCH72
		Position Controller Unit for CJ1 PLC
		CJ1W-NCF71 (16 axes)
		CJ1W-NC471 (4 axes) CJ1W-NC271 (2 axes)
	Position Controller Unit for CS1 PLC	CS1W-NCF71 (16 axes)
		CS1W-NC471 (4 axes)
		CS1W-NC271 (2 axes)

Computer software

Specifications	Model
Configuration and monitoring software tool for servo drives and inverters. (CX-drive version 1.70 or higher)	CX-drive
Complete OMRON software package including CX-drive. (CX-One version 3.10 or higher)	CX-One

MECHATROLINK-II cables (for CN6)

Symbol	Specifications	Length	Model
⑩	MECHATROLINK-II Terminator resistor	-	JEPMC-W6022-E
	MECHATROLINK-II cables	0.5 m	JEPMC-W6003-A5-E
		1 m	JEPMC-W6003-01-E
		3 m	JEPMC-W6003-03-E
		5 m	JEPMC-W6003-05-E
		10 m	JEPMC-W6003-10-E
		20 m	JEPMC-W6003-20-E
		30 m	JEPMC-W6003-30-E

Filters

Symbol	Applicable servodrive	Filter model	Rated current	Leakage current	Rated voltage
⑪	R88D-GN01H□ R88D-GN02H□	R88A-FIK102-RE	2.4 A	3.5 mA	250 VAC single-phase
	R88D-GN04H□	R88A-FIK104-RE	4.1 A	3.5 mA	
	R88D-GN08H□	R88A-FIK107-RE	6.6 A	3.5 mA	
	R88D-GN10H□ R88D-GN15H□	R88A-FIK114-RE	14.2 A	3.5 mA	

External regenerative resistor

Symbol	Regenerative resistor unit model	Specifications
⑫	R88A-RR08050S	50 Ω, 80 W
	R88A-RR080100S	100 Ω, 80 W
	R88A-RR22047S	47 Ω, 220 W
	R88A-RR50020S	20 Ω, 500 W

ALL DIMENSIONS SHOWN ARE IN MILLIMETERS.
To convert millimeters into inches, multiply by 0.03937. To convert grams into ounces, multiply by 0.03527.